

Traction machine series

## ZFW320

Loading: 320-630Kg, S Dia.: 320mm

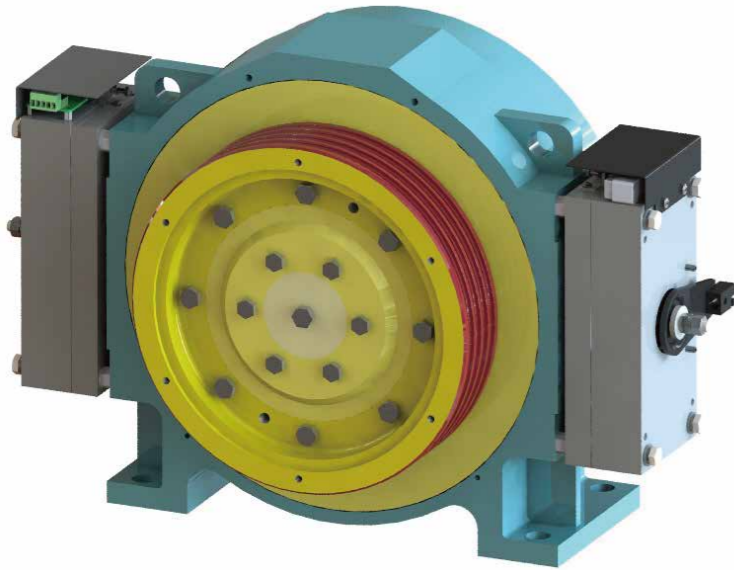

Max.axle load(Kg)	2500
Motor Weight(Kg)	260
Wrap	Single
Working duty	S5-40%
Starts Per Hour(F/h)	240
IP.Code	IP41
Ins.Class	F
Energy Efficiency Grade	Level 3
Brake type	HEB-K2
Brake voltage(V)	DC110
Brake current(A)	2x1.3

## Overall Dimensions

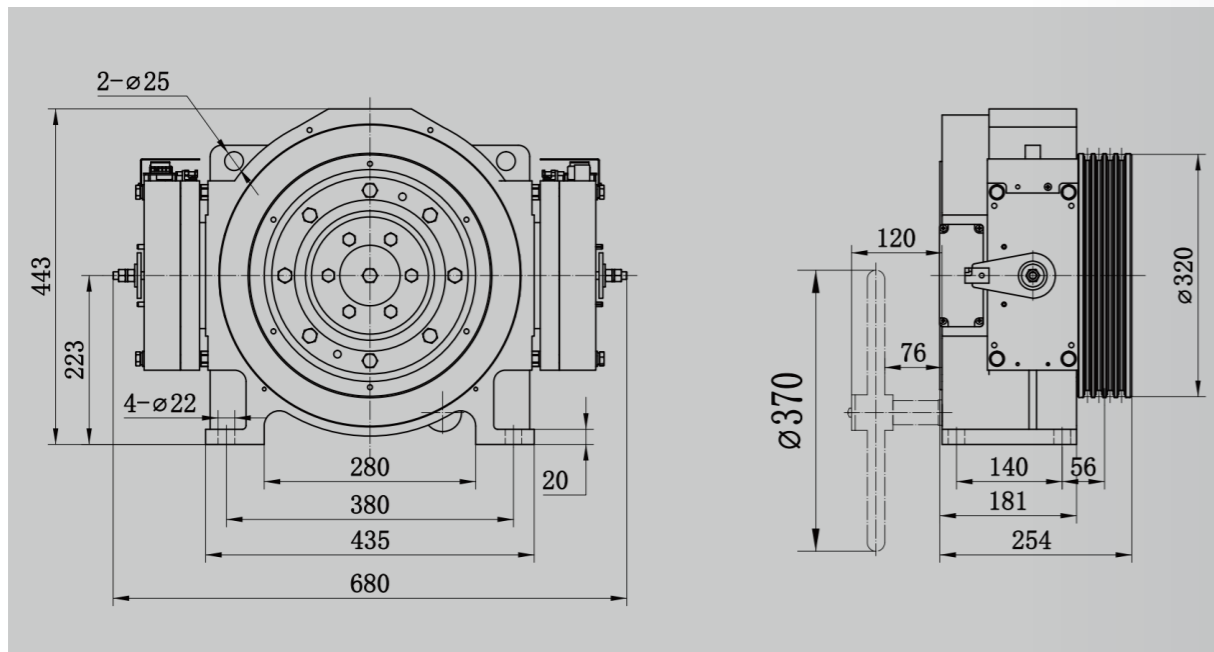

## ZFW400L

Loading: 630-1050Kg, S Dia.: 400mm

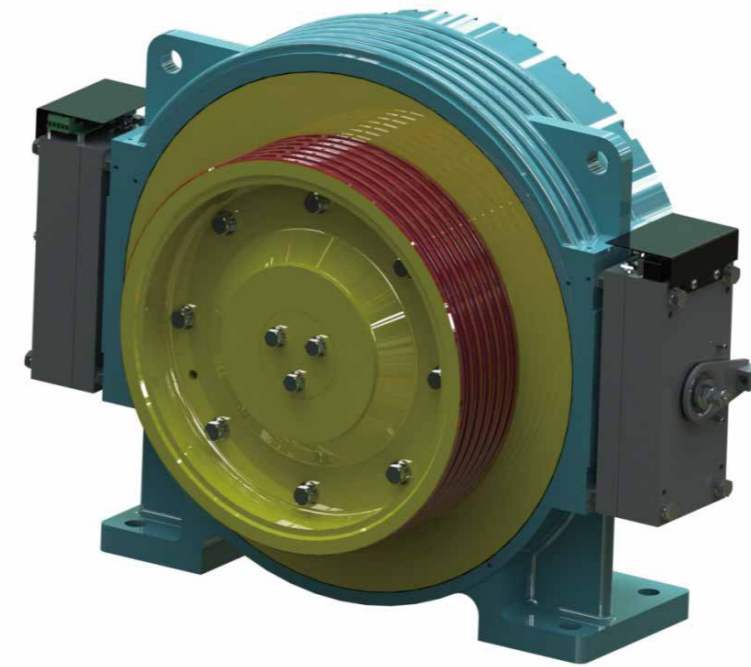

Max.axle load(Kg)	4000
Motor Weight(Kg)	350
Wrap	Single
Working duty	S5-40%
Starts Per Hour(F/h)	240
IP.Code	IP41
Ins.Class	F
Energy Efficiency Grade	Level 3
Brake type	HEB-K2
Brake voltage(V)	DC110
Brake current(A)	2X1.3

## Overall Dimensions

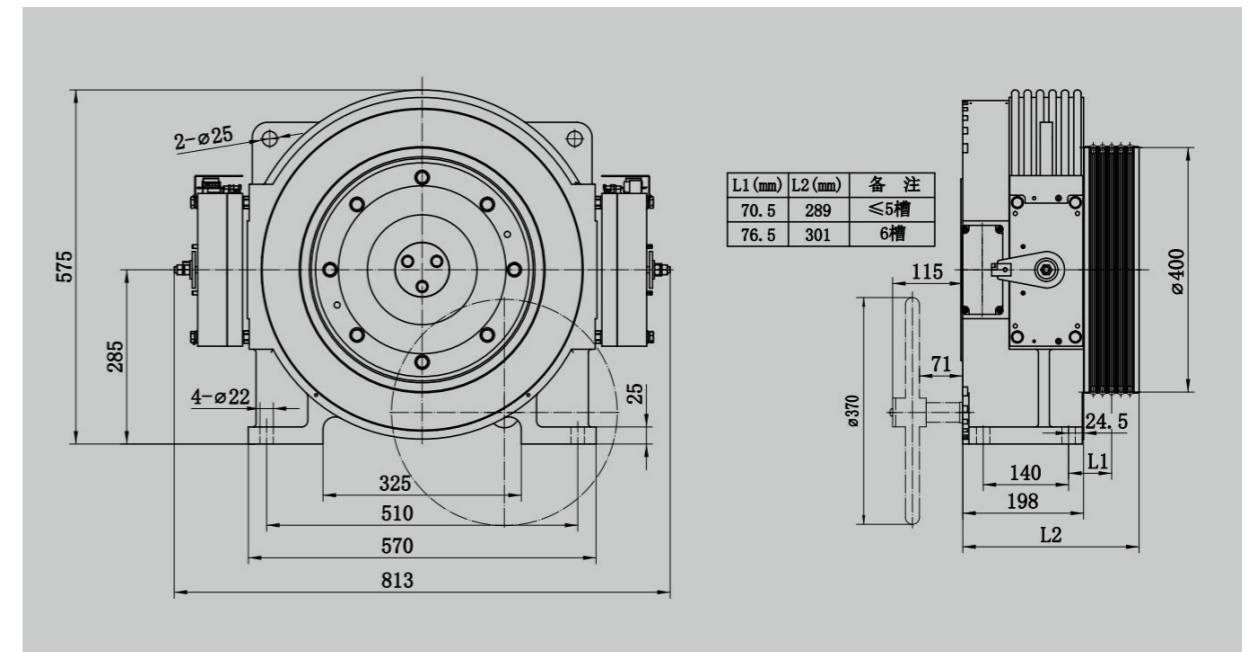

## ZFW400L

Loading: 630-825Kg, S Dia.: 450mm

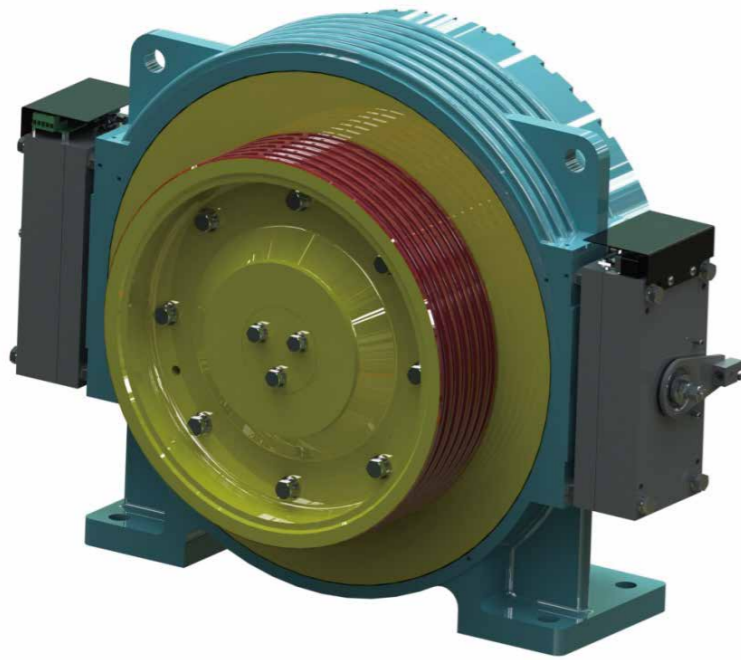

Max.axle load(Kg)	4000
Motor Weight(Kg)	330
Wrap	Single
Working duty	S5-40%
Starts Per Hour(F/h)	240
IP.Code	IP41
Ins.Class	F
Energy Efficiency Grade	Level 3
Brake type	HEB-K2
Brake voltage(V)	DC110
Brake current(A)	2X1.3

## ZFW400L

Loading: 1000-1150Kg, S Dia.: 400/450mm

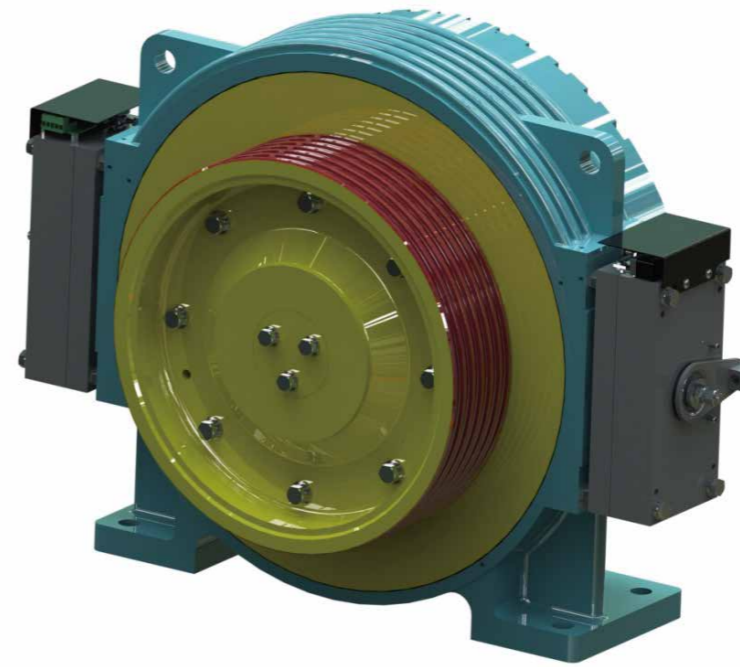

Max.axle load(Kg)	4000
Motor Weight(Kg)	370
Wrap	Single
Working duty	S5-40%
Starts Per Hour(F/h)	240
IP.Code	IP41
Ins.Class	F
Energy Efficiency Grade	Level 3
Brake type	HEB-K2
Brake voltage(V)	DC110
Brake current(A)	2X1.3

## Overall Dimensions

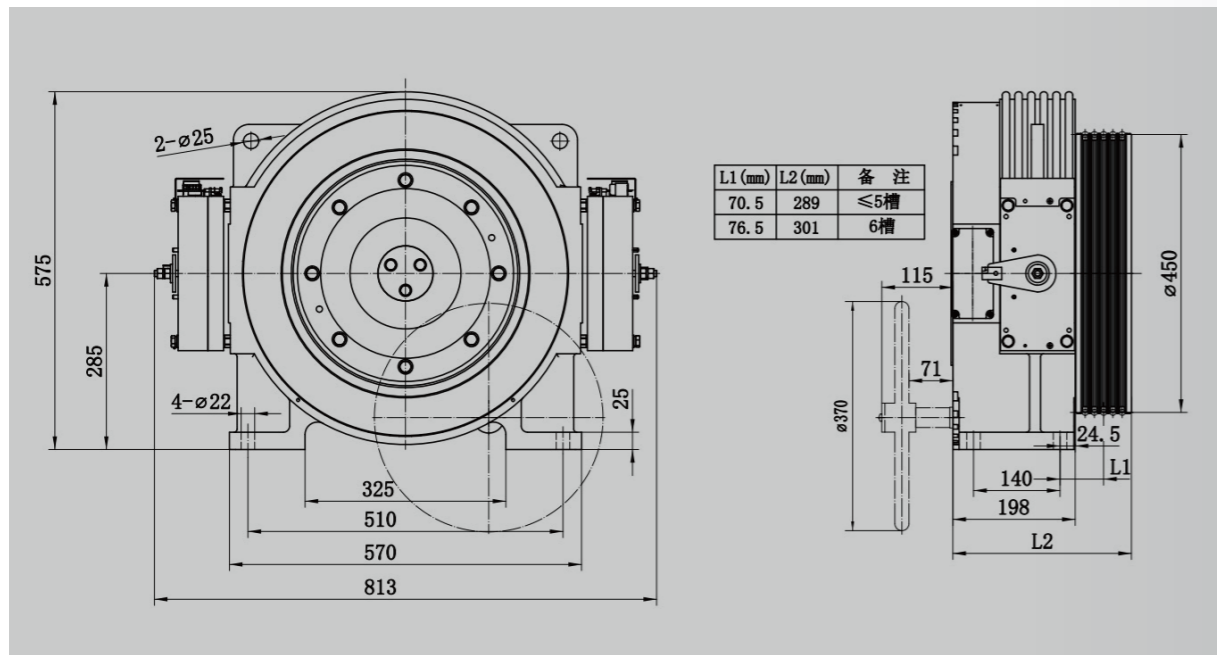

## Overall Dimensions

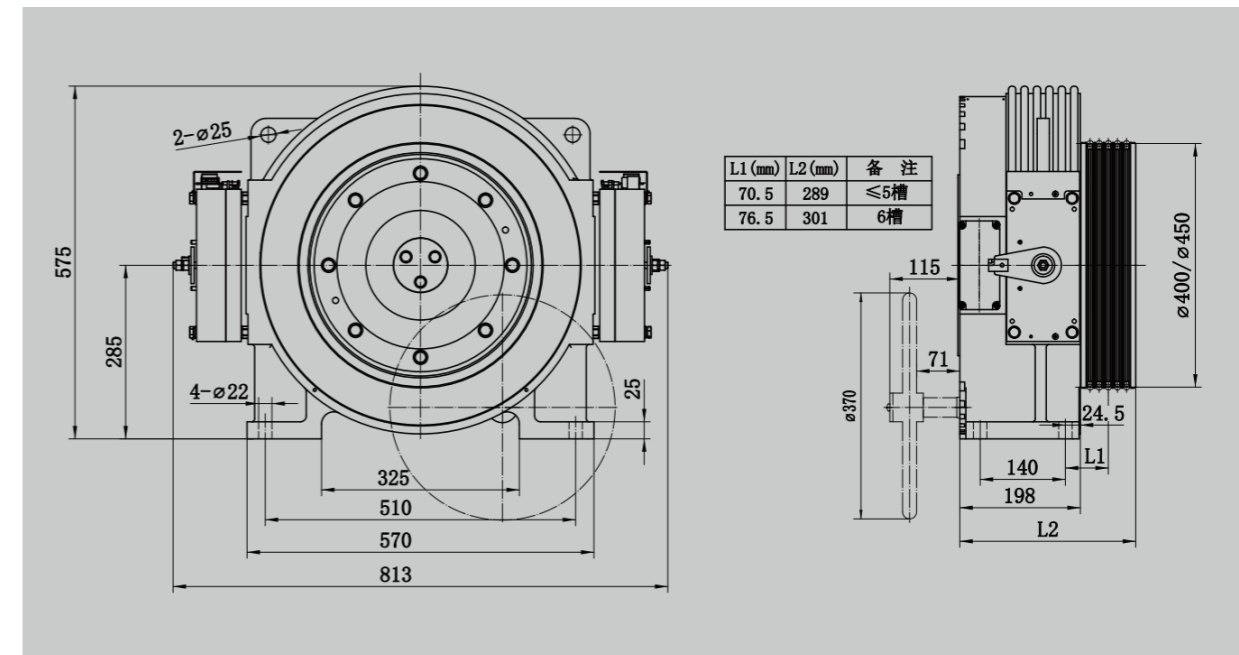



## ZFW400L

Loading: 1250-1600Kg, S Dia.: 400/480mm



Max.axle load(Kg)	6000
Motor Weight(Kg)	570
Wrap	Single
Working duty	S5-40%
Starts Per Hour(F/h)	240
IP.Code	IP41
Ins.Class	F
Energy Efficiency Grade	Level 3
Brake type	HEB-K1
Brake voltage(V)	DC110
Brake current(A)	2X1.6

## Overall Dimensions

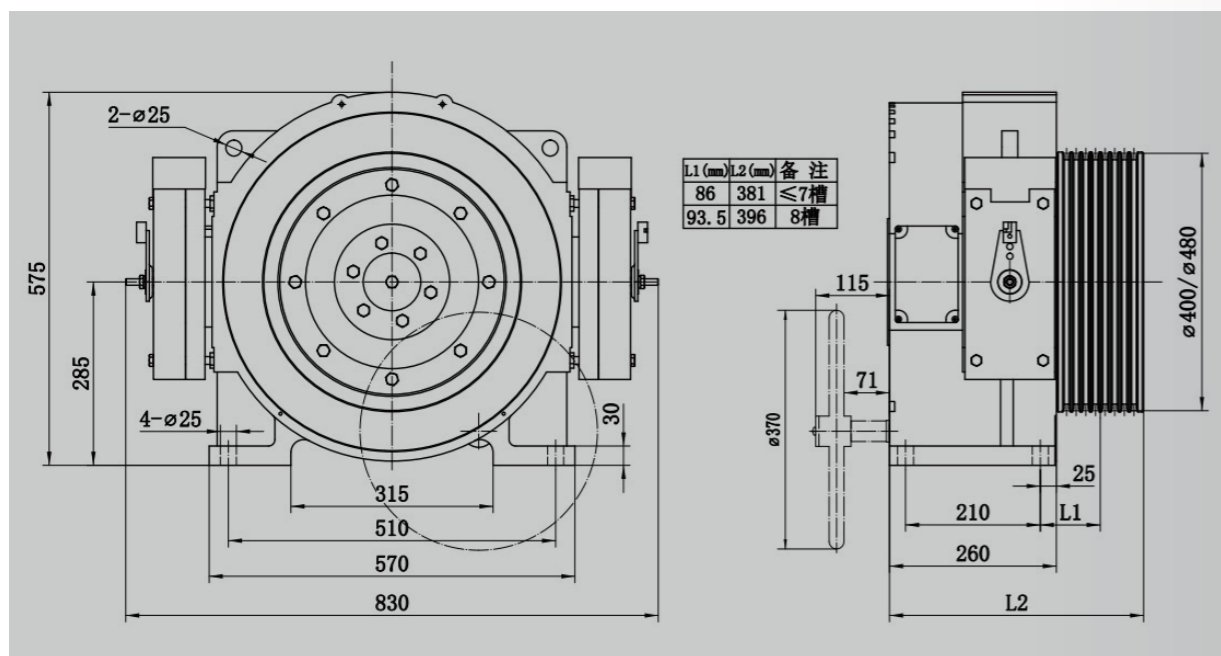

## ZFW480

Loading: 1250-1600Kg, S Dia.: 450/550mm

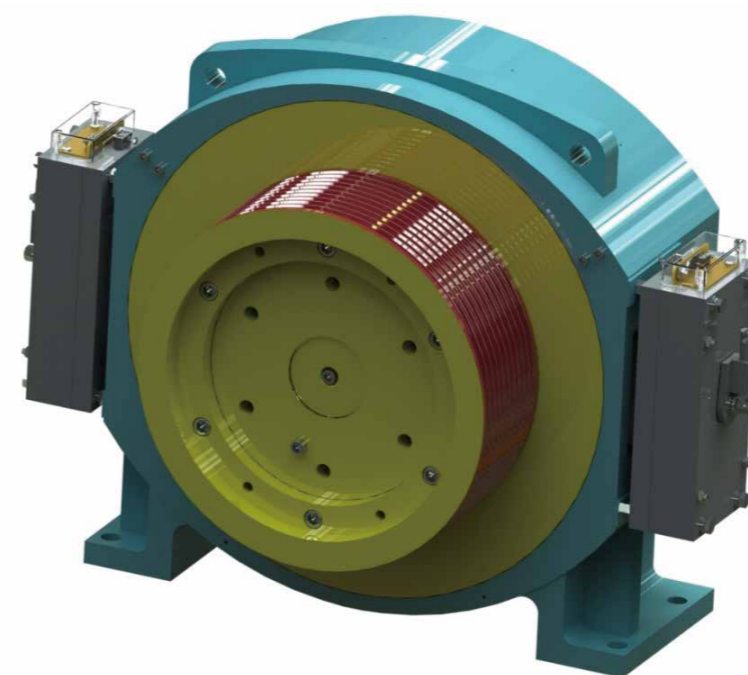

Max.axle load(Kg)	10000
Motor Weight(Kg)	780
Wrap	Single
Working duty	S5-40%
Starts Per Hour(F/h)	240
IP.Code	IP41
Ins.Class	F
Energy Efficiency Grade	Level 3
Brake type	HEB-K3
Brake voltage(V)	DC110
Brake current(A)	2X2.2

## Overall Dimensions

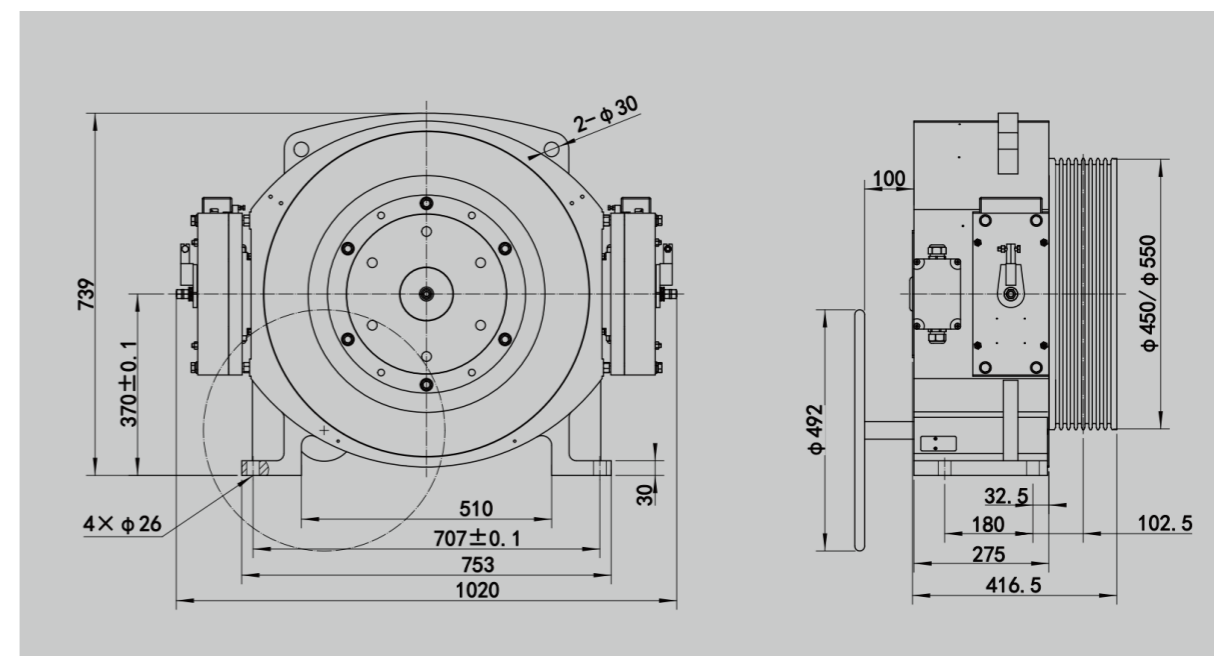

## ZFW480

Loading: 2000-2500Kg, S Dia.: 450/480mm

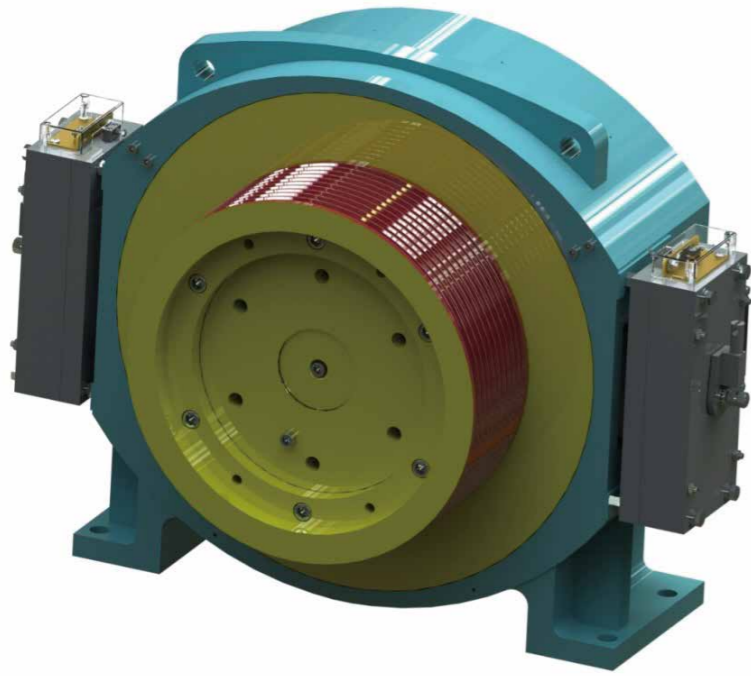

Max.axle load(Kg)	10000
Motor Weight(Kg)	830
Wrap	Single
Working duty	S5-40%
Starts Per Hour(F/h)	240
IP.Code	IP41
Ins.Class	F
Energy Efficiency Grade	Level 3
Brake type	HEB-K3
Brake voltage(V)	DC110
Brake current(A)	2X2.2

## Overall Dimensions

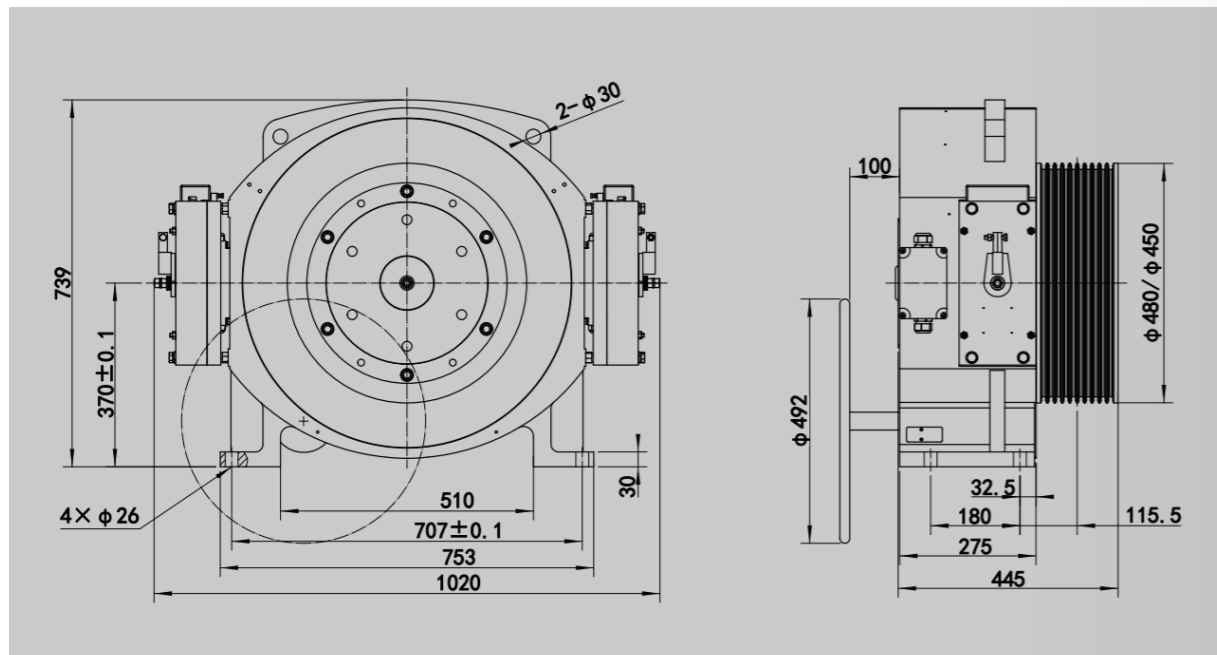

## ZFN320

Loading: 630-1150Kg, S Dia: 320mm

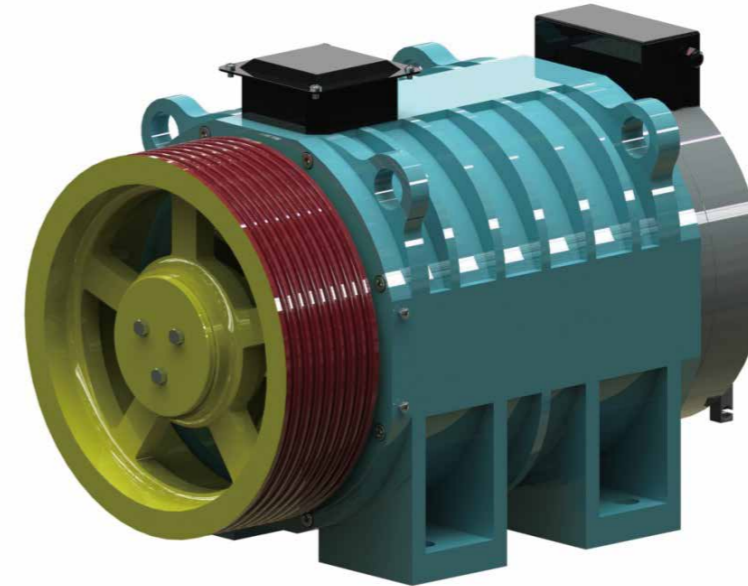

Max.axle load(Kg)	3500
Motor Weight(Kg)	300
Wrap	Single
Working duty	S5-40%
Starts Per Hour(F/h)	240
IP.Code	IP41
Ins.Class	F
Energy Efficiency Grade	Level 3
Brake type	HEB-Z2
Brake voltage(V)	DC110
Brake current(A)	2.6

## Overall Dimensions

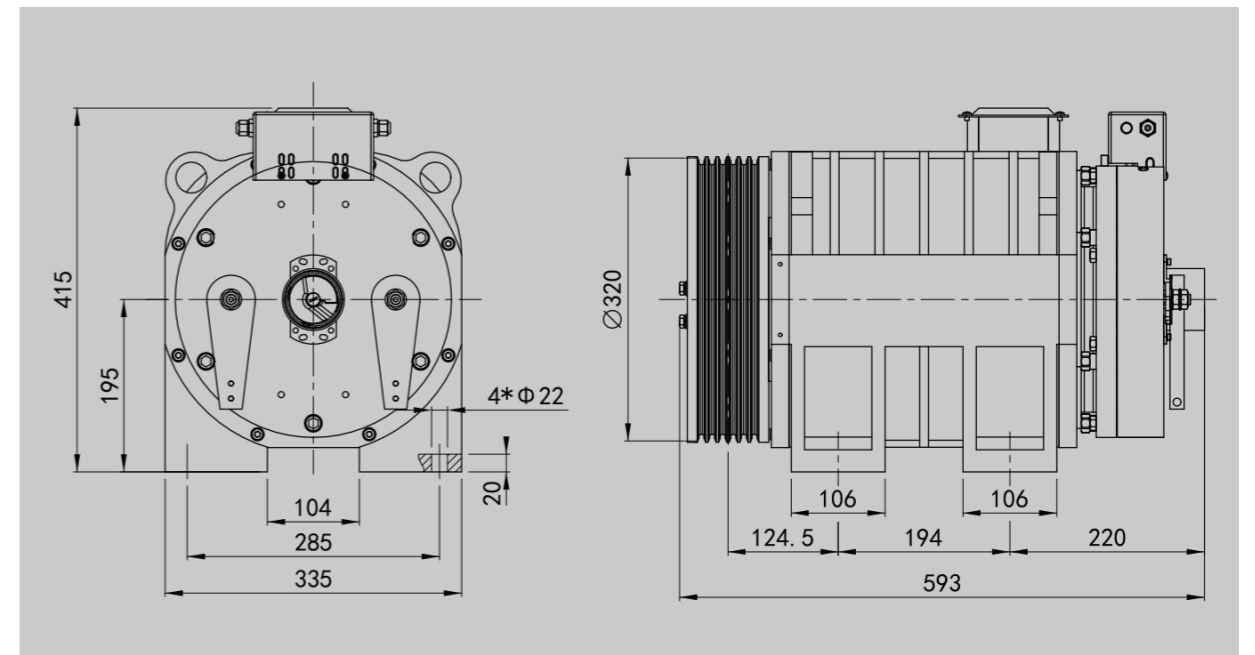

## ZFN450

Loading: 1600-3000Kg, S Dia.: 450mm



Max.axle load(Kg)	12000
Motor Weight(Kg)	850
Wrap	Single
Working duty	S5-40%
Starts Per Hour(F/h)	240
IP.Code	IP41
Ins.Class	F
Energy Efficiency Grade	Level 3
Brake type	HEB-Z1
Brake voltage(V)	DC110
Brake current(A)	2X2.5

## Overall Dimensions

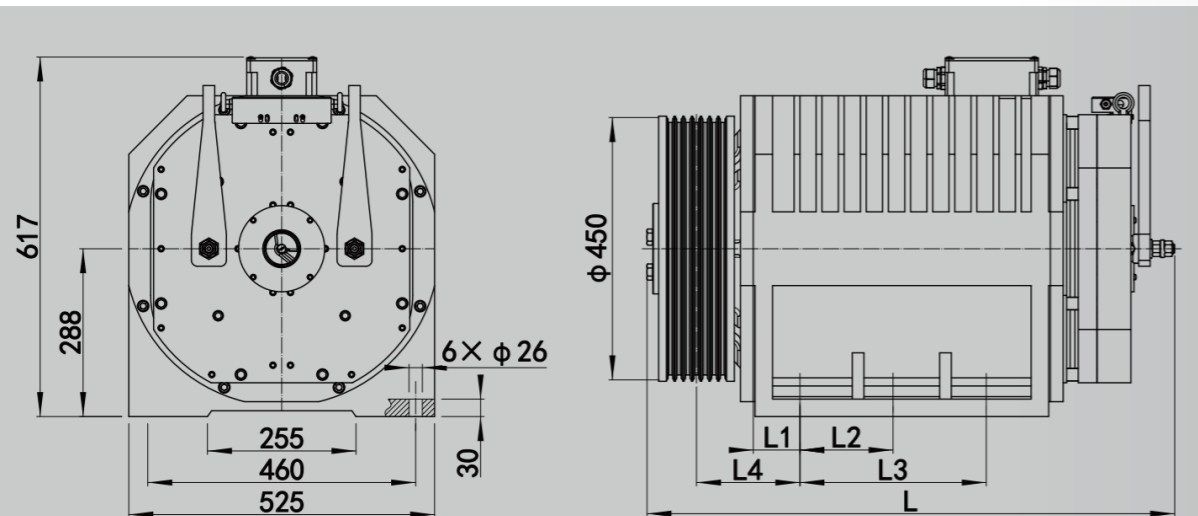

額定載重 (kg)	梯速 (m/s)	L (mm)	L1 (mm)	L2 (mm)	L3 (mm)	L4 (mm)
1600	0.5-3.0	804	70	194	/	172
2000	0.5-3.0	804	70	194	/	172
2500	0.5-3.0	804	70	127	254	170
3000	0.5-3.0	926	80	160	320	190

## ZFN450

Loading: 1600-3000Kg, S Dia.: 480mm

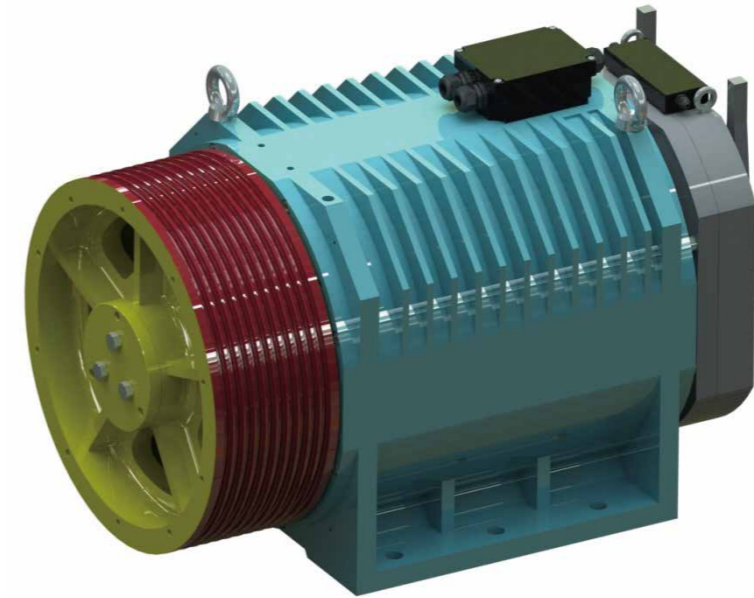

Max.axle load(Kg)	12000
Motor Weight(Kg)	860
Wrap	Single
Working duty	S5-40%
Starts Per Hour(F/h)	240
IP.Code	IP41
Ins.Class	F
Energy Efficiency Grade	Level 3
Brake type	HEB-Z1
Brake voltage(V)	DC110
Brake current(A)	2X2.5

## Overall Dimensions

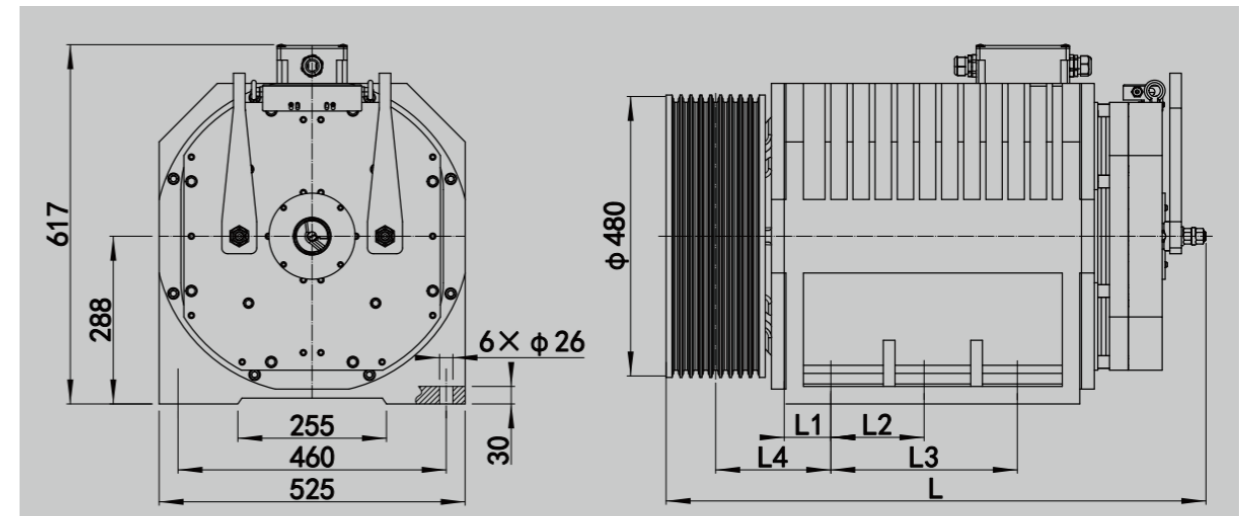

額定載重 (kg)	梯速 (m/s)	L (mm)	L1 (mm)	L2 (mm)	L3 (mm)	L4 (mm)
1600	0.5-3.0	820	70	194	/	180
2000	0.5-3.0	820	70	194	/	180
2500	0.5-3.0	820	70	127	254	178
3000	0.5-3.0	926	80	160	320	197.5



## ZFN450

Loading: 1600-3000Kg, S Dia.: 520mm



Max.axle load(Kg)	12000
Motor Weight(Kg)	900
Wrap	Single
Working duty	S5-40%
Starts Per Hour(F/h)	240
IP.Code	IP41
Ins.Class	F
Energy Efficiency Grade	Level 3
Brake type	HEB-Z1
Brake voltage(V)	DC110
Brake current(A)	2X2.5

## ZFN200

Loading: 320-450Kg, S Dia.: 200/240mm

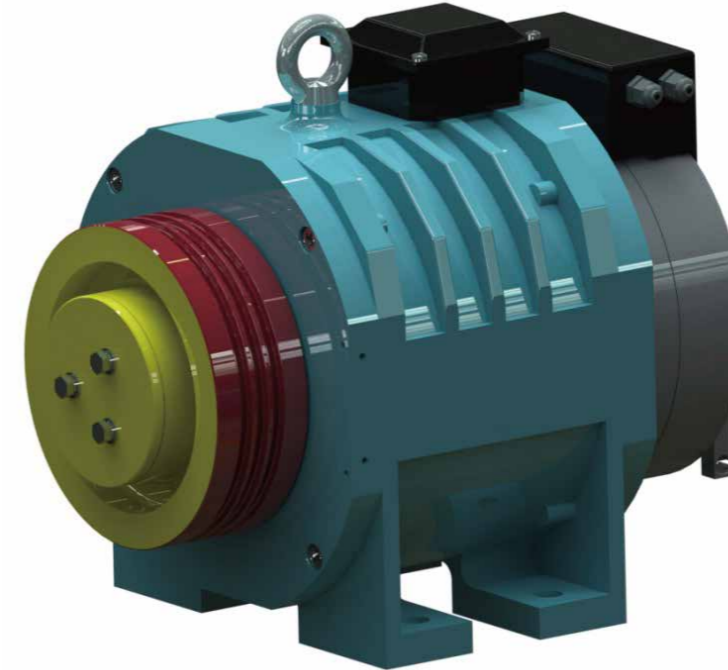

Max.axle load(Kg)	2500
Motor Weight(Kg)	160
Wrap	Single
Working duty	S5-40%
Starts Per Hour(F/h)	240
IP.Code	IP41
Ins.Class	F
Energy Efficiency Grade	Level 3
Brake type	HEB-Z3
Brake voltage(V)	DC110
Brake current(A)	2.6

## Overall Dimensions

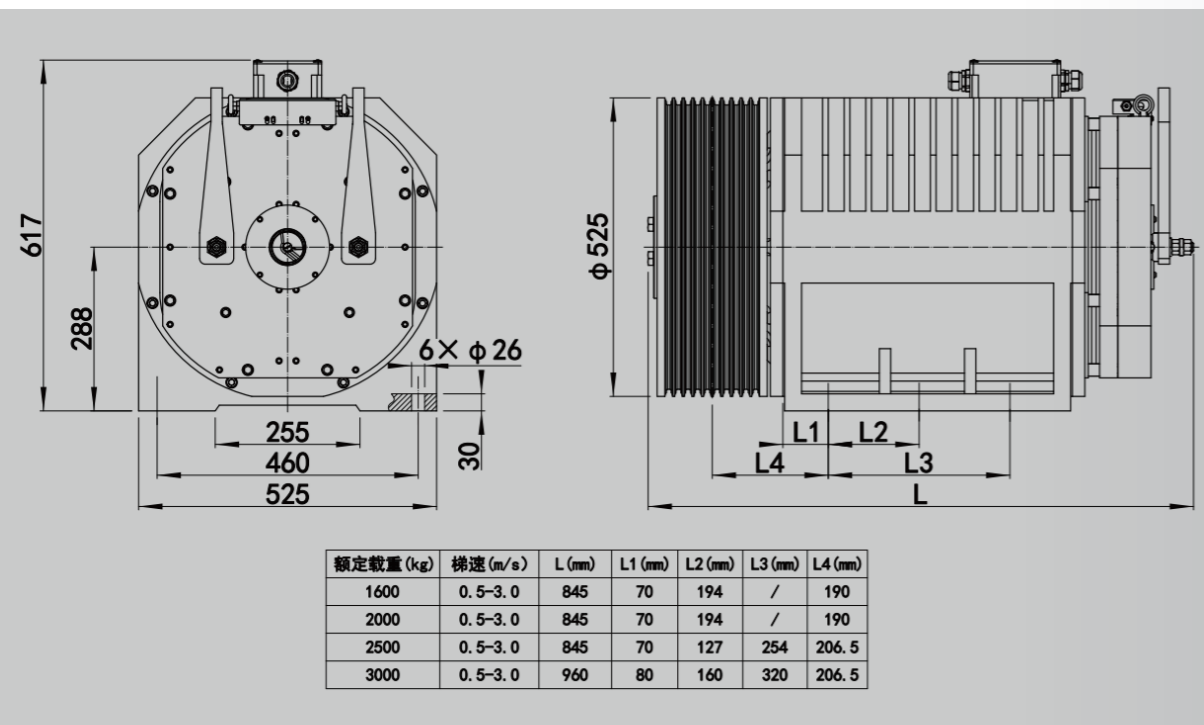

## Overall Dimensions

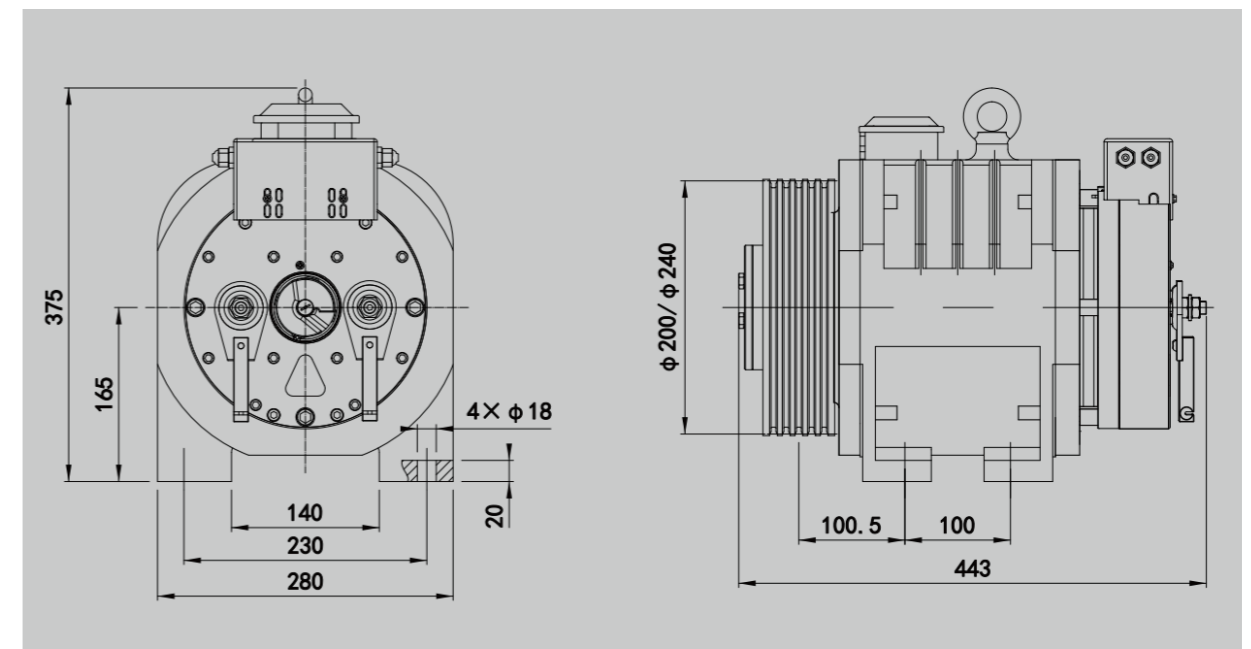

## ZFN200A

Loading: 320-450Kg, S Dia.: 200/240mm



Max.axle load(Kg)	2500
Motor Weight(Kg)	160
Wrap	Single
Working duty	S5-40%
Starts Per Hour(F/h)	240
IP.Code	IP41
Ins.Class	F
Energy Efficiency Grade	Level 3
Brake type	HEB-Z3
Brake voltage(V)	DC110
Brake current(A)	2.6

## Overall Dimensions

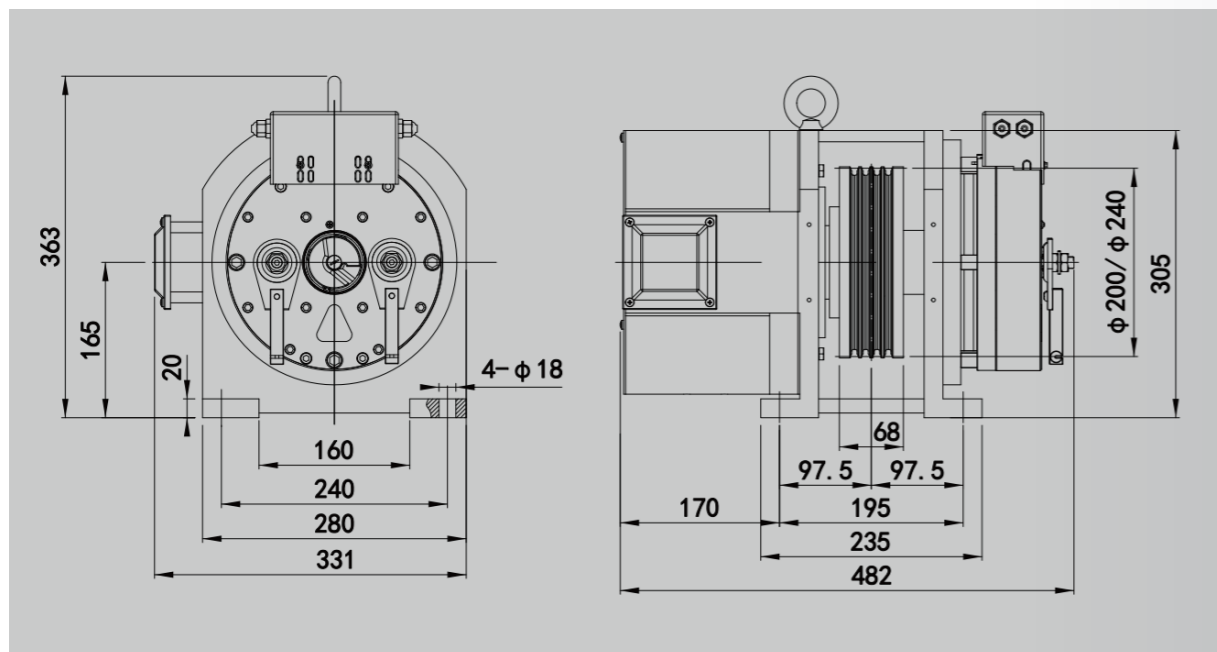

## ZFG100

Loading: 320-630Kg, S Dia.: 100mm

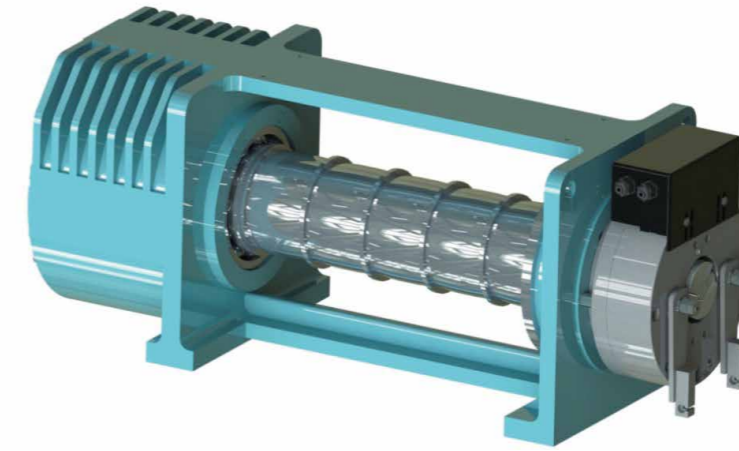

Max.axle load(Kg)	2500
Motor Weight(Kg)	140
Wrap	Single
Working duty	S5-40%
Starts Per Hour(F/h)	240
IP.Code	IP41
Ins.Class	F
Energy Efficiency Grade	Level 3
Brake type	HEB-Z3
Brake voltage(V)	DC110
Brake current(A)	1.8

## Overall Dimensions

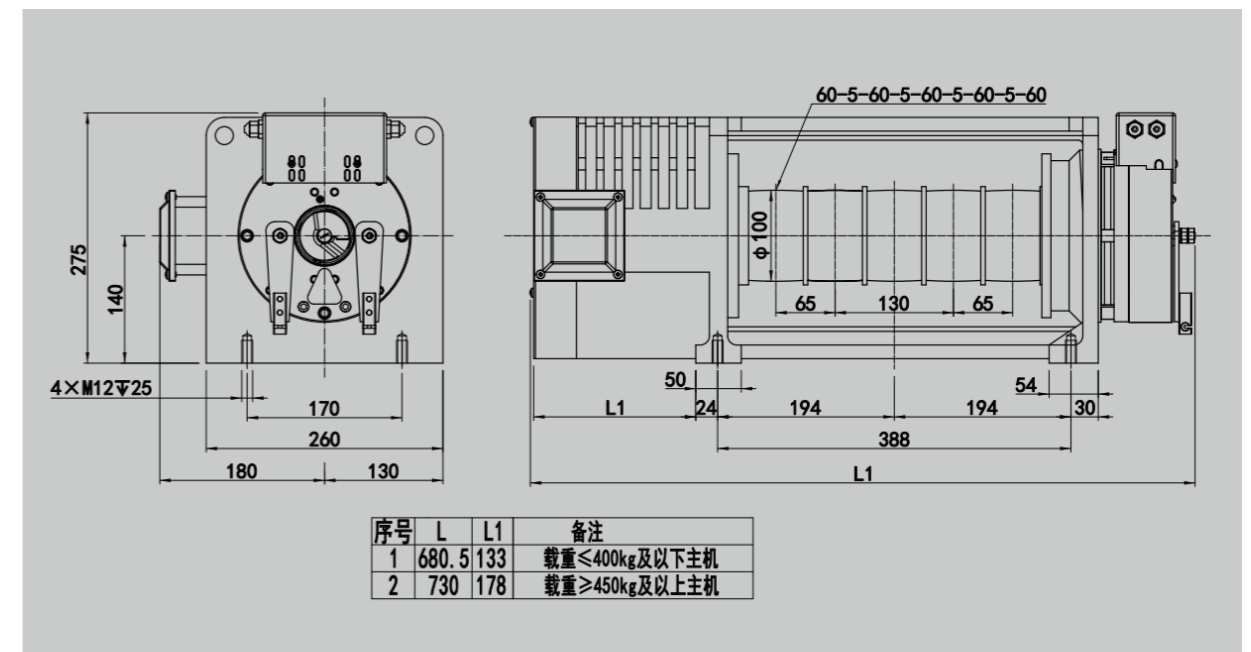



## ZFG87

Loading: 320-450Kg, S Dia.: 87mm

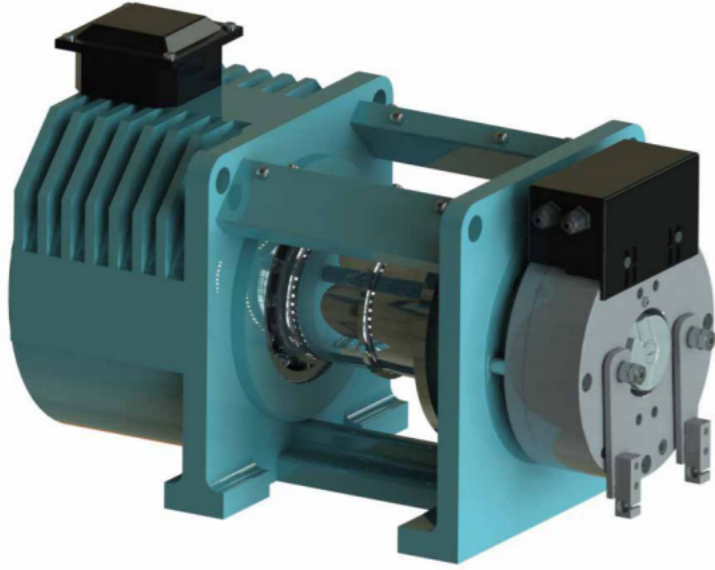

Max.axle load(Kg)	2000
Motor Weight(Kg)	80
Wrap	Single
Working duty	S5-40%
Starts Per Hour(F/h)	240
IP.Code	IP41
Ins.Class	F
Energy Efficiency Grade	Level 3
Brake type	HEB-Z3
Brake voltage(V)	DC110
Brake current(A)	1.8

### Overall Dimensions

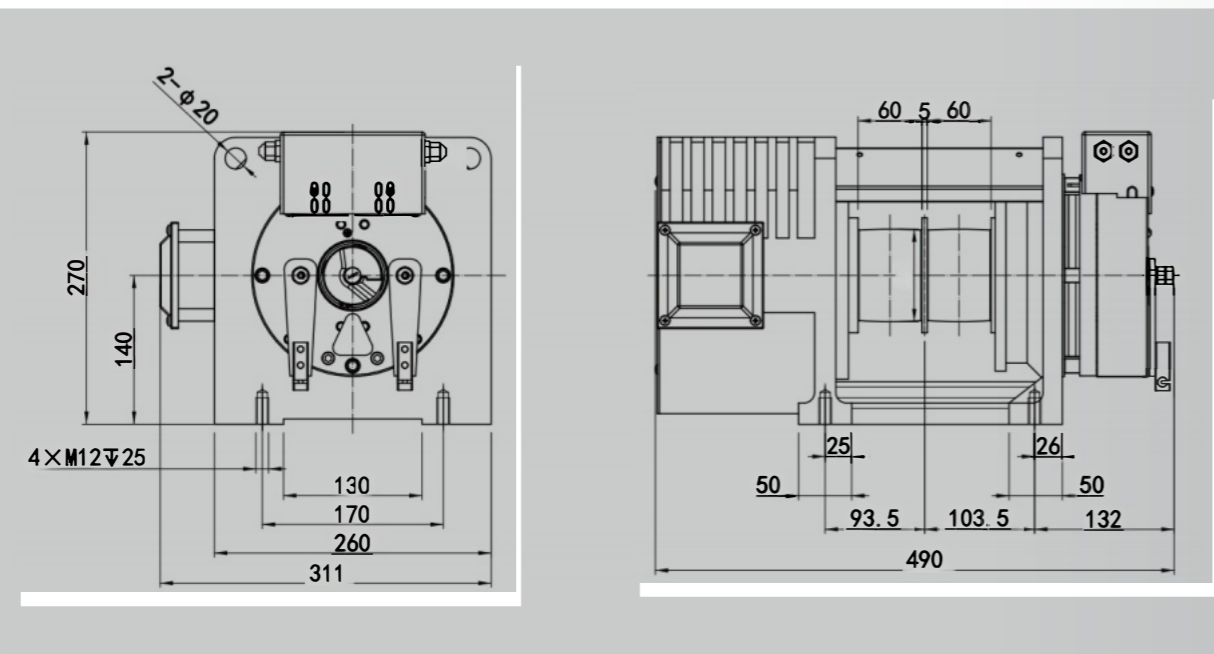

## ZFG65

Loading: 320-400Kg, S Dia.: 65mm

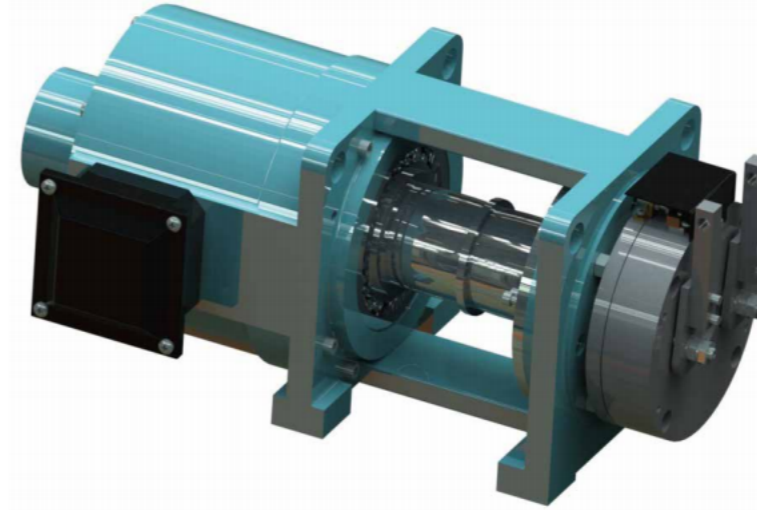

Max.axle load(Kg)	1000
Motor Weight(Kg)	60
Wrap	Single
Working duty	S5-40%
Starts Per Hour(F/h)	240
IP.Code	IP41
Ins.Class	F
Energy Efficiency Grade	Level 3
Brake type	HEB-Z3
Brake voltage(V)	DC110
Brake current(A)	1.5

### Overall Dimensions

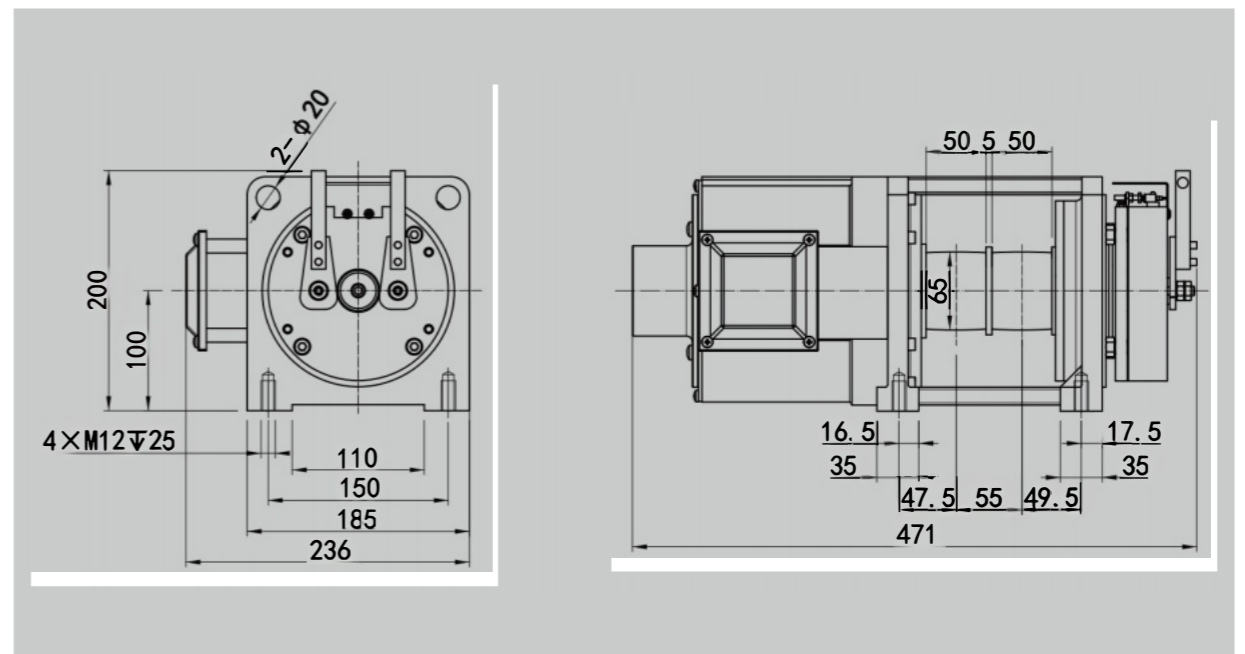

Customer Selection Table										
Ratio	Loading Ladder speed	Household ladder series				Outer rotor series				
		Rated load(Kg)								
		320-400	320-450	320-630	320-450	320-630	630-1050	630-1600	1250-2500	
2:1	S P E E D (m /S)	0.3								
		0.4	ZFG65 ø65mm							
		0.5		ZFG87 ø87mm	ZFG100 ø100mm	ZFN200 ZFN200A ø200mm ø240mm				
		0.63								
		1.0				ZFW320 ø320mm				
		1.5					ZFW400 ø400mm	ZFW400L ø400mm ø450mm ø480mm		
		1.75							ZFW480 ø450mm ø480mm ø520mm ø550mm	
		2.0								
		2.5								
3.0										
4:1		0.5								
		1.0								
8:1		0.5								

Customer Selection Table										
Ratio	Loading Ladder speed	Bar machine series			Large load series					
		Rated load(Kg)								
		630-1150	1250-1600	1600-3000	1600-2000	3000-5000	3000-6000	8000-10000	8000-12000	
2:1	S P E E D (m /S)	0.3								
		0.4								
		0.5								
		0.63								
		1.0	ZFN320 ø320mm	ZFN450 ø450mm ø480mm ø520mm						
		1.5								
		1.75								
		2.0								
		2.5								
3.0										
4:1		0.5			ZFW400L ø400mm ø450mm ø480mm	ZFN320 ø320mm	ZFW480 ø450mm ø520mm ø550mm	ZFN450 ø450mm ø480mm ø520mm		
		1.0								
8:1		0.5						ZFW480 ø450mm ø480mm	ZFN450 ø450mm ø480mm ø520mm	